

Submersible pumps in stainless steel

-  Sewage water
-  Domestic use
-  Civil use
-  Industrial use



PERFORMANCE RANGE

- Flow rate up to **650 l/min** (39 m³/h)
- Head up to **16 m**

APPLICATION LIMITS

- **5 m** maximum immersion depth
- Maximum liquid temperature **+40 °C**
- Passage of solids:
 - up to **Ø 40 mm** for VX /35-ST
 - up to **Ø 50 mm** for VX /50-ST
- Minimum immersion depth for continuous service:
 - **280 mm** for VX /35-ST
 - **300 mm** for VX /50-ST

CONSTRUCTION AND SAFETY STANDARDS

- **10 m** long power cable
- Float switch for single-phase versions

EN 60335-1
IEC 60335-1
CEI 61-150

EN 60034-1
IEC 60034-1
CEI 2-3



CERTIFICATIONS

Company with management system certified DNV
ISO 9001: QUALITY

INSTALLATION AND USE

The **VX-ST** submersible pumps in stainless steel are recommended for draining **sewage water** in domestic, civil and industrial applications, in every case where there are solid bodies in suspension, for example water mixed with mud, groundwater, surface water. They are suitable for draining flooded areas such as cellars, underground car parks, car washes, for emptying cesspools and for sewage disposal. These pumps distinguish themselves for their reliability, which can be best appreciated under automatic operating conditions in fixed installations.

PATENTS - TRADE MARKS - MODELS

- Patent n. EP2313658
- Patent n. IT0001428923

OPTIONS AVAILABLE ON REQUEST

- Single-phase pumps without float switch
- AISI 316L stainless steel pump shaft
- Other voltages

GUARANTEE

2 years subject to terms and conditions

CHARACTERISTIC CURVES AND PERFORMANCE DATA

60 Hz n= 3450 min⁻¹

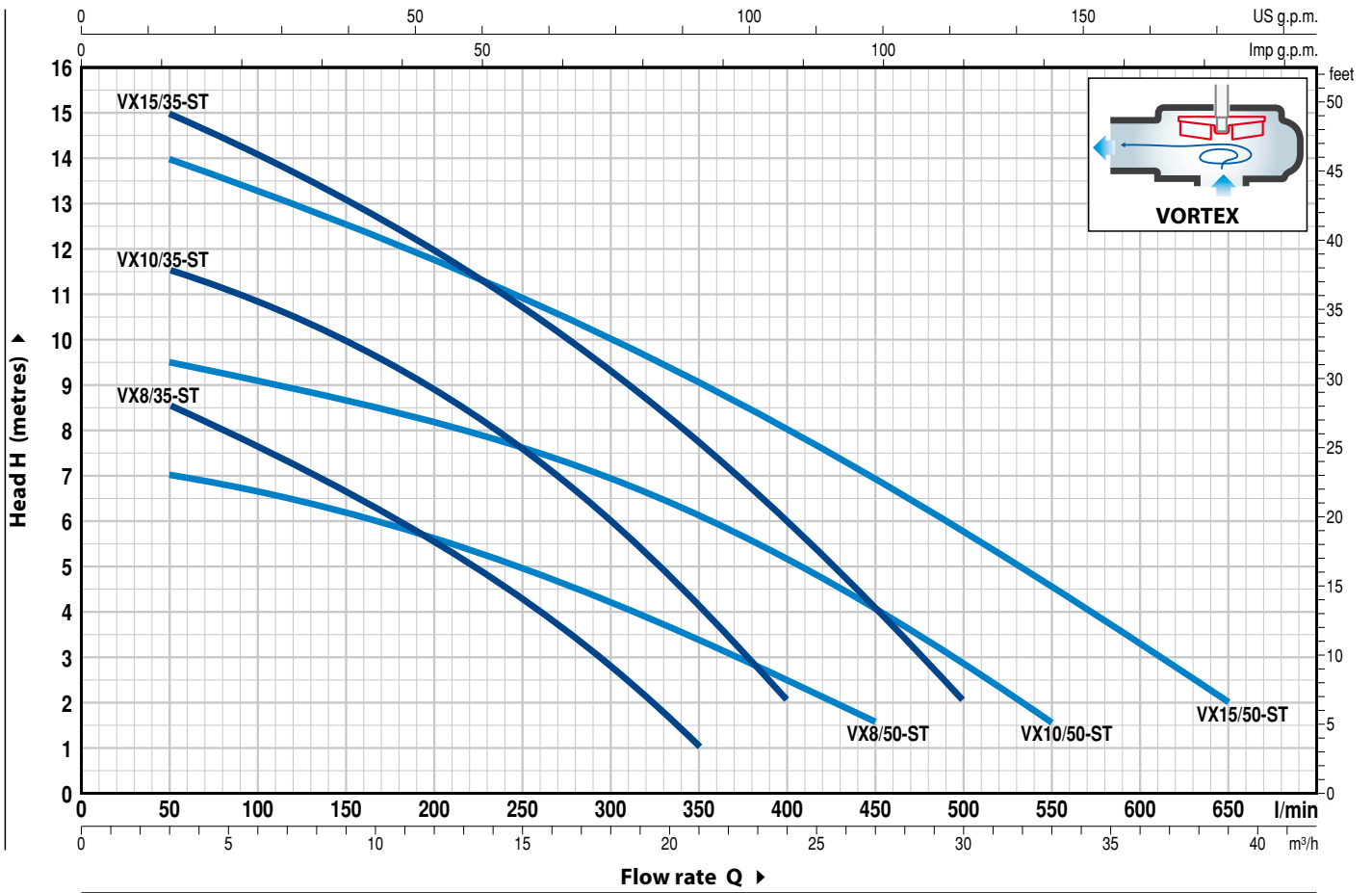

MODEL		POWER (P ₂)		Q	Flow rate															
Single-phase	Three-phase	kW	HP		m ³ /h	0	3	6	12	18	21	24	27	30	33	36	39			
				l/min	0	50	100	200	300	350	400	450	500	550	600	650				
VXm 8/35 -ST	VX 8/35 -ST	0.55	0.75	H metres	9.5	8.5	7.5	5.4	2.7	1										
VXm 10/35 -ST	VX 10/35 -ST	0.75	1		12	11.5	10.7	8.8	6	4	2									
VXm 15/35 -ST	VX 15/35 -ST	1.1	1.5		16	15	14	12	9.2	7.7	6	4.1	2							
VXm 8/50 -ST	VX 8/50 -ST	0.55	0.75		7.5	7	6.6	5.7	4.2	3.5	2.5	1.5								
VXm 10/50 -ST	VX 10/50 -ST	0.75	1		10	9.5	9.2	8.5	7	6	5	3.8	2.7	1.5						
VXm 15/50 -ST	VX 15/50 -ST	1.1	1.5		14.5	14	13.3	11.7	10	9	8	7	5.8	4.7	3.3	2				

Q = Flow rate H = Total manometric head

Tolerance of characteristic curves in compliance with EN ISO 9906 Grade 3B.

POS. COMPONENT CONSTRUCTION CHARACTERISTICS

1 PUMP BODY	Stainless steel AISI 304 with threaded port in compliance with ISO 228/1				
2 BASE	Stainless steel AISI 304				
3 IMPELLER	Stainless steel AISI 304 VORTEX type				
4 MOTOR CASING	Stainless steel AISI 304				
5 MOTOR CASING PLATE	Stainless steel AISI 304				
6 MOTOR SHAFT	Stainless steel AISI 431				
7 SHAFT WITH DOUBLE MECHANICAL SEAL SEPARATED BY AN OIL CHAMBER					
Seal Model	Shaft Diameter	Position	Stationary ring	Rotational ring	Elastomer
MG1-14D SIC	Ø 14 mm	Motor side	Silicon carbide	Graphite	NBR
		Pump side	Silicon carbide	Silicon carbide	NBR
8 BEARINGS	6203 ZZ / 6203 ZZ				

9 CAPACITOR

Pump	Capacitance	
<i>Single-phase</i>	<i>(220 V)</i>	<i>(110 V or 127 V)</i>
VXm 8/35 -ST	20 µF 450 VL	30 µF - 250 VL
VXm 8/50 -ST		
VXm 10/35-ST		
VXm 10/50-ST	25 µF 450 VL	-
VXm 15/35-ST		
VXm 15/50-ST		

10 ELECTRIC MOTOR

VXm: single-phase 220 V - 60 Hz
with thermal overload protector incorporated into the winding

VX: three-phase 380 V - 60 Hz

- Insulation: class F
- Protection: IP X8

11 POWER CABLE

"H07 RN-F" type
(with Schuko plug for single-phase versions only)

Standard length 10 metres

12 FLOAT SWITCH

(only for single-phase versions)

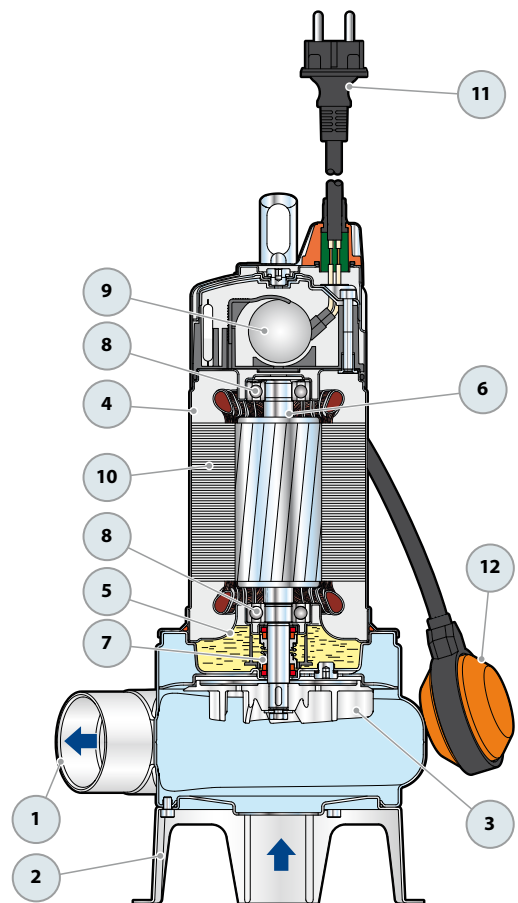

DIMENSIONS AND WEIGHT

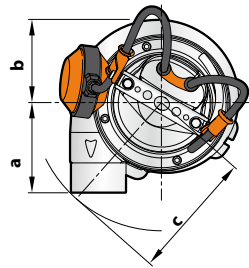
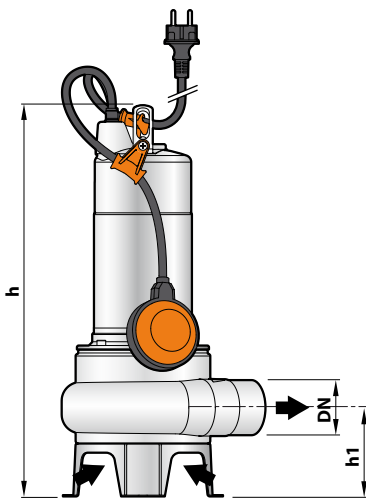

Standard installation

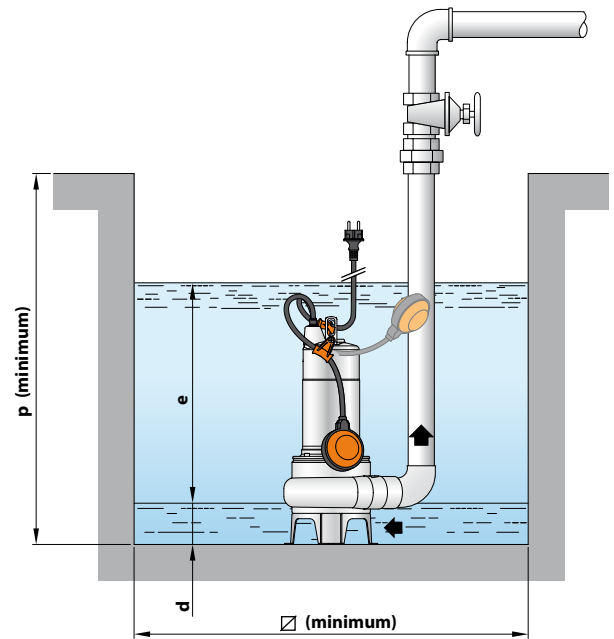

MODEL		PORT DN	Passage of solids	DIMENSIONS mm										kg	
Single-phase	Three-phase			a	b	c	h	h1	d	e	p	Ø	1~	3~	
VXm 8/35 -ST	VX 8/35 -ST	1½"	Ø 40 mm	95	95	140	406	87	50	variable	500	500	10.6	10.6	
VXm 10/35 -ST	VX 10/35 -ST						421						11.6	10.7	
VXm 15/35 -ST	VX 15/35 -ST						432						13.0	11.9	
VXm 8/50 -ST	VX 8/50 -ST	2"	Ø 50 mm	102	140	140	432	102	60	variable	500	500	11.0	10.8	
VXm 10/50 -ST	VX 10/50 -ST						447						11.0	10.8	
VXm 15/50 -ST	VX 15/50 -ST						447						13.1	12.1	

ABSORPTION

MODEL	VOLTAGE		
	220 V	110 V	127 V
Single-phase	220 V	110 V	127 V
VXm 8/35 -ST	3.8 A	7.6 A	6.6 A
VXm 10/35 -ST	6.0 A	13.0 A	11.0 A
VXm 15/35 -ST	8.2 A	-	-
VXm 8/50 -ST	3.8 A	7.6 A	6.6 A
VXm 10/50 -ST	6.0 A	13.0 A	11.0 A
VXm 15/50 -ST	8.5 A	-	-

MODEL	VOLTAGE		
	220 V	380 V	440 V
Three-phase	220 V	380 V	440 V
VX 8/35 -ST	3.2 A	1.8 A	1.6 A
VX 10/35 -ST	4.2 A	2.4 A	2.2 A
VX 15/35 -ST	6.3 A	3.6 A	3.0 A
VX 8/50 -ST	3.3 A	2.0 A	1.6 A
VX 10/50 -ST	4.0 A	2.3 A	2.0 A
VX 15/50 -ST	6.2 A	3.6 A	3.1 A

PALLETIZATION

MODEL		GROUPAGE n. pumps	CONTAINER n. pumps
Single-phase	Three-phase		
VXm 8/35 -ST	VX 8/35 -ST	60	80
VXm 10/35 -ST	VX 10/35 -ST	60	80
VXm 15/35 -ST	VX 15/35 -ST	54	72
VXm 8/50 -ST	VX 8/50 -ST	54	72
VXm 10/50 -ST	VX 10/50 -ST	54	72
VXm 15/50 -ST	VX 15/50 -ST	54	72

SEWAGE LIFTING SYSTEM VX-ST – BC-ST

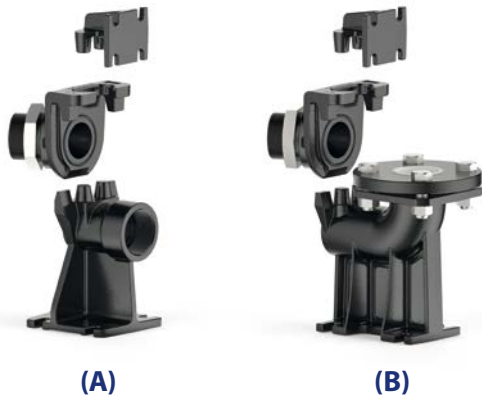

(A)

(B)



A) HORIZONTAL DELIVERY VERSION WITH ¾" GUIDE TUBES

For VX /35-ST	Cod. ASSPVX35ST	DN 2"
For VX /50-ST , BC /50-ST	Cod. ASSPVX50ST	DN 2"

Kit consisting of:

- footing connection
- slide guide with ring nut and seal
- support for the guide tubes

B) VERTICAL DELIVERY VERSION WITH ¾" GUIDE TUBES

For VX /35-ST	Cod. ASSPVX35STV	DN 2½"
For VX /50-ST, BC /50-ST	Cod. ASSPVX50STV	DN 2½"

Kit consisting of:

- footing connection complete with counterflange
- slide guide with ring nut and seal
- support for the guide tubes

STANDARD INSTALLATION

1. Pump
2. Footing connection
3. Guide tubes
4. Support for the guide tubes
5. Lifting chain
6. Control box
7. Alarm float switch
8. Starting float switch
9. Stop float switch
10. Non-return valve

SLIDE GUIDE (Also to be ordered separately)

For VX /35-ST	Cod. ASSFL005
For VX /50-ST , BC /50-ST	Cod. ASSFL005

Complete with ring nut and seal

● INTERMEDIATE SUPPORT (To be ordered separately)

Cod. 859SV340INTFA	For guide tubes Ø ¾"
--------------------	----------------------



In order to ensure stability, insert the intermediate support every 2 metres

GUIDE TUBES (AISI 304 stainless steel)

Cod. 54SARTG005	Ø ¾"
-----------------	------

Maximum length of the tube plank: 6 metres

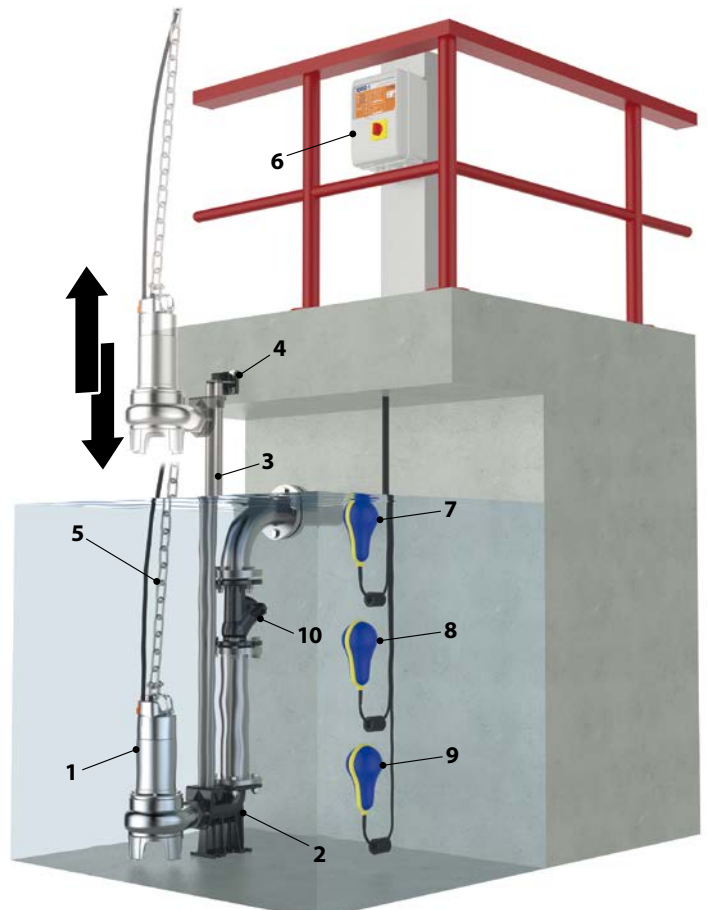

DIMENSIONS (Horizontal delivery version)

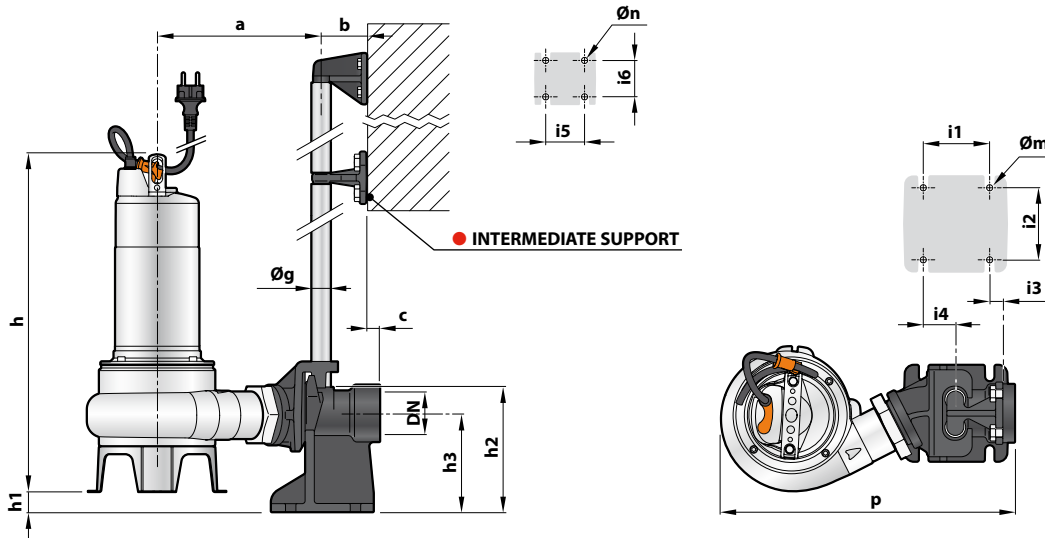

MODEL		Passage of solids mm	PORT DN	DIMENSIONS mm																	
Single-phase	Three-phase			a	b	c	p	h	h1	h2	h3	i1	i2	i3	i4	i5	i6	Øg	Øm	Øn	
VXm 8/35 -ST	VX 8/35 -ST	40	2"	207	61	17	379	406	43	130	165	85	94	16	40	50	48	¾"	12	11	
VXm 10/35 -ST	VX 10/35 -ST							421													
VXm 15/35 -ST	VX 15/35 -ST							430													
VXm 8/50 -ST	VX 8/50 -ST	50	2"	217	61	17	388	445	28	130	165	85	94	16	40	50	48	¾"	12	11	
VXm 10/50 -ST	VX 10/50 -ST							430													
VXm 15/50 -ST	VX 15/50 -ST							445													
BCm 10/50 -ST	BC 10/50 -ST							430													
BCm 15/50 -ST	BC 15/50 -ST							445													

DIMENSIONS (Vertical delivery version)

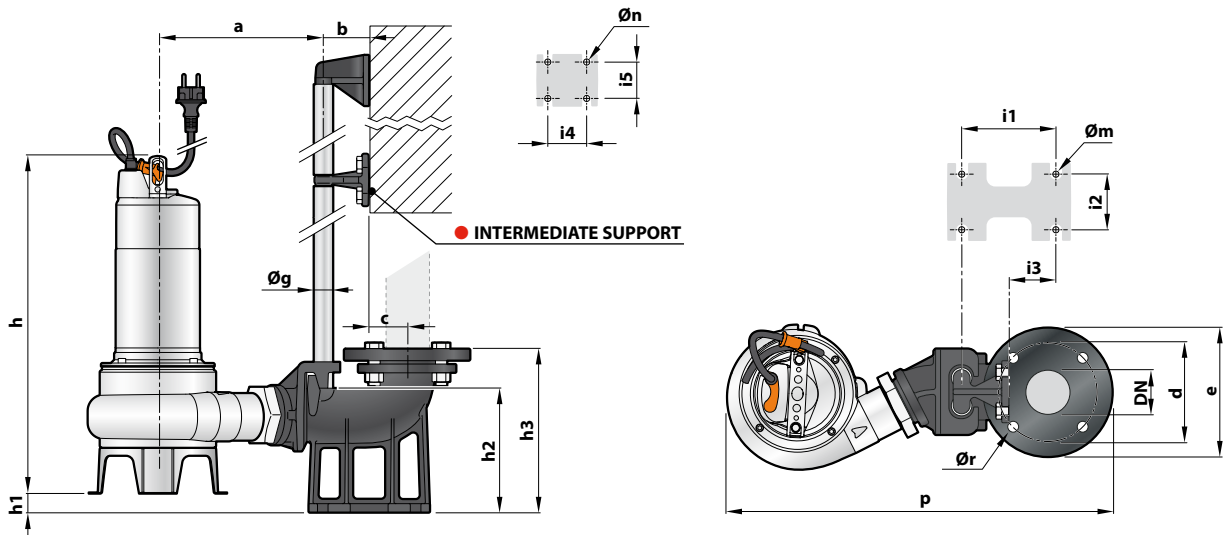

MODEL		Passage of solids mm	PORT DN	DIMENSIONS mm																		
Single-phase	Three-phase			a	b	c	d	e	p	h	h1	h2	h3	i1	i2	i3	i4	i5	Øg	Øm	Øn	Ør
VXm 8/35 -ST	VX 8/35 -ST	40	2"	207	61	52	125	165	495	406	40	164	215	120	72	62	50	48	¾"	14	11	18
VXm 10/35 -ST	VX 10/35 -ST									421												
VXm 15/35 -ST	VX 15/35 -ST									430												
VXm 8/50 -ST	VX 8/50 -ST	50	2½"	217	61	52	125	165	507	445	26	164	215	120	72	62	50	48	¾"	14	11	18
VXm 10/50 -ST	VX 10/50 -ST									430												
VXm 15/50 -ST	VX 15/50 -ST									445												
BCm 10/50 -ST	BC 10/50 -ST									430												
BCm 15/50 -ST	BC 15/50 -ST									445												