

RX-VORTEX

Submersible pumps

 Dirty water

 Domestic use

 Civil use



PERFORMANCE RANGE

- Flow rate up to **380 l/min** (22.8 m³/h)
- Head up to **13 m**

APPLICATION LIMITS

- **10 m** maximum immersion depth (with a sufficiently long power cable)
- Maximum liquid temperature **+50 °C** (Maximum liquid temperature +90 °C for a maximum of 3 minutes intermittent service)
- Passage of solids:
 - up to **Ø 20 mm** for RX 2/20, RX 3/20
 - up to **Ø 40 mm** for RX 4/40, RX 5/40
- Suction level:
 - **25 mm** above ground level for RX 2/20, RX 3/20
 - **50 mm** above ground level for RX 4/40, RX 5/40
- Continuous service **S1**

CONSTRUCTION AND SAFETY STANDARDS

The pumps are complete with:

- **5 m** long power cable for RX 2/20, RX 3/20
- **10 m** long power cable for RX 4/40, RX 5/40
- float switch for single-phase versions

EN 60335-1
IEC 60335-1
CEI 61-150

EN 60034-1
IEC 60034-1
CEI 2-3



CERTIFICATIONS

Company with management system certified DNV
ISO 9001: QUALITY

INSTALLATION AND USE

The **RX-VORTEX** series pumps are suitable for use with **dirty water**. The design solutions that have been adopted, such as the complete cooling of the motor, guarantee the reliability of the pump. They are suitable for use in domestic applications such as for discharging dirty water containing suspended solids.

PATENTS - TRADE MARKS - MODELS

- Patent n. EP2313658
- Patent n. IT0001428923

OPTIONS AVAILABLE ON REQUEST

- “**RX-VORTEX GM**” pumps with a vertical float switch (suitable for particularly small wells)
- Special mechanical seal
- RX 2-3/20 pumps with a **10 m** long power cable
 - ➔ N.B.: Standard EN 60335-2-41 states that the power cable must be 10 m long for outdoor applications
- Single-phase pumps without float switch
- Other voltages

GUARANTEE

2 years subject to terms and conditions

CHARACTERISTIC CURVES AND PERFORMANCE DATA

60 Hz n= 3450 min⁻¹

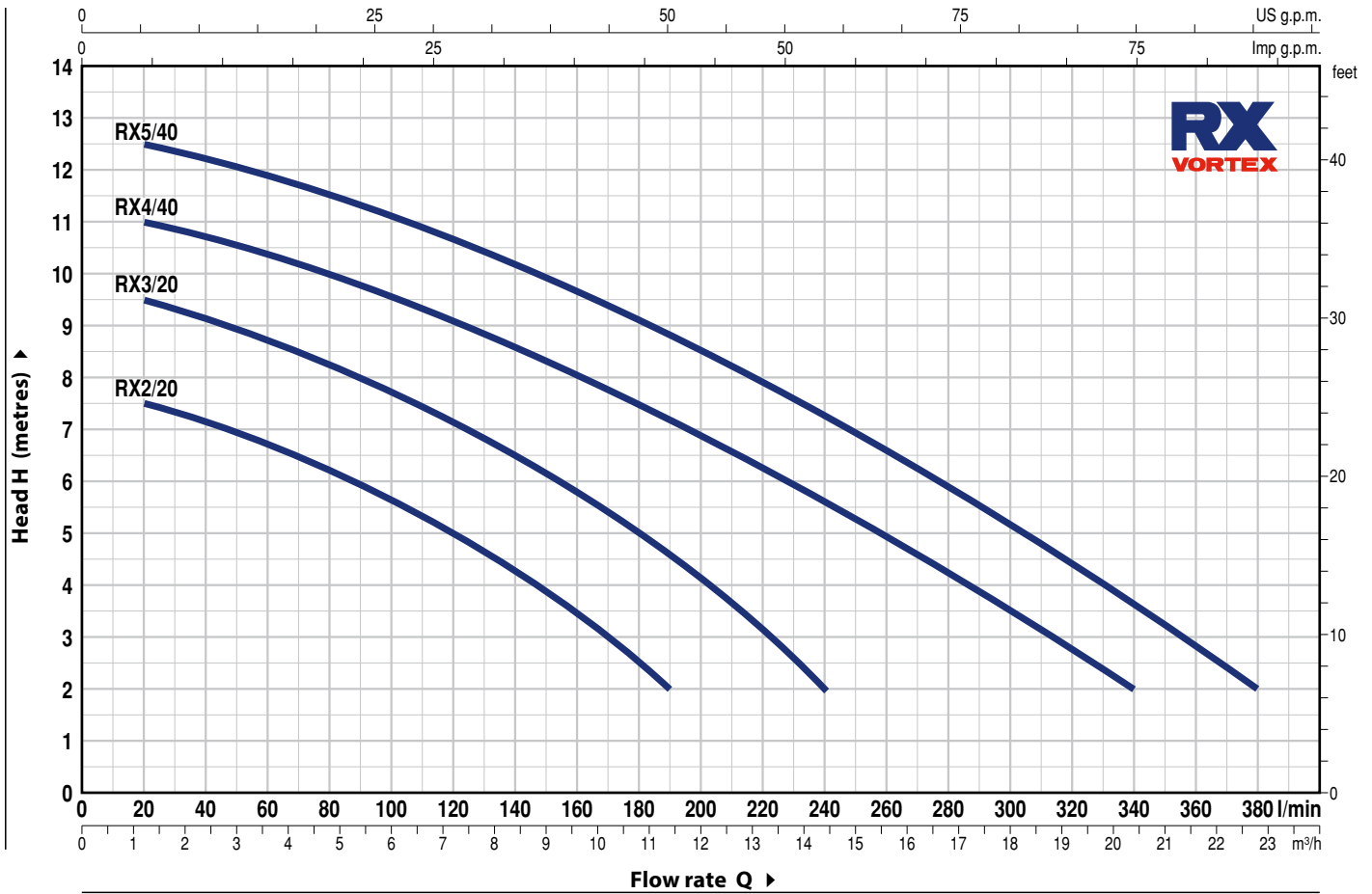

MODEL		POWER (P ₂)		Q	H metres																	
Single-phase	Three-phase	kW	HP		m ³ /h	0	1.2	2.4	3.6	4.8	6	7.2	8.4	9.6	11.4	13.2	14.4	20.4	22.8			
				l/min	0	20	40	60	80	100	120	140	160	190	220	240	340	380				
RXm 2/20	RX 2/20	0.37	0.50	H metres	8	7.5	7.1	6.7	6.2	5.7	5	4.3	3.4	2								
RXm 3/20	RX 3/20	0.55	0.75		10	9.5	9.1	8.7	8.2	7.7	7.1	6.5	5.8	4.6	3.2	2						
RXm 4/40	RX 4/40	0.75	1		11.2	11	10.7	10.4	10	9.5	9	8.5	8	7.1	6.2	5.6	2					
RXm 5/40	RX 5/40	1.1	1.5		13	12.5	12.2	11.9	11.5	11.1	10.6	10.1	9.6	8.8	7.9	7.3	3.6	2				

Q = Flow rate H = Total manometric head

Tolerance of characteristic curves in compliance with EN ISO 9906 Grade 3B.

POS. COMPONENT CONSTRUCTION CHARACTERISTICS

1	PUMP BODY	Stainless steel AISI 304 with threaded port in compliance with ISO 228/1
2	SUCTION FILTER	Stainless steel AISI 304
3	DIFFUSER	Stainless steel AISI 304
4	IMPELLER	Stainless steel AISI 304 VORTEX type
5	MOTOR CASING	Stainless steel AISI 304
6	MOTOR CASING PLATE	Stainless steel AISI 304
7	MOTOR SHAFT	Stainless steel AISI 431

8 SHAFT WITH DOUBLE SEAL AND OIL CHAMBER

Seal Model	Shaft Diameter	Stationary ring	Materials	
			Rotational ring	Elastomer
STA-12R SIC	Ø 12 mm	Ceramic	Silicon carbide	NBR

9 **LIP SEAL** Ø 12 x Ø 19 x H 5 mm

10 **BEARINGS** 6201 ZZ / 6201 ZZ

11 CAPACITOR

Pump Single-phase	Capacitance	
	(220 V)	(110 V or 127 V)
RXm 2/20	10 µF - 450 VL	16 µF - 250 VL
RXm 3/20	14 µF - 450 VL	16 µF - 250 VL

12 ELECTRIC MOTOR

RXm: single-phase 220 V - 60 Hz
with thermal overload protector incorporated into the winding
RX: three-phase 380 V - 60 Hz
– Insulation: class F
– Protection: IP X8

13 POWER CABLE

"H07 RN-F" type
(with Schuko plug for single-phase versions only)
Standard length 5 metres

14 FLOAT SWITCH

(Only for single-phase versions)

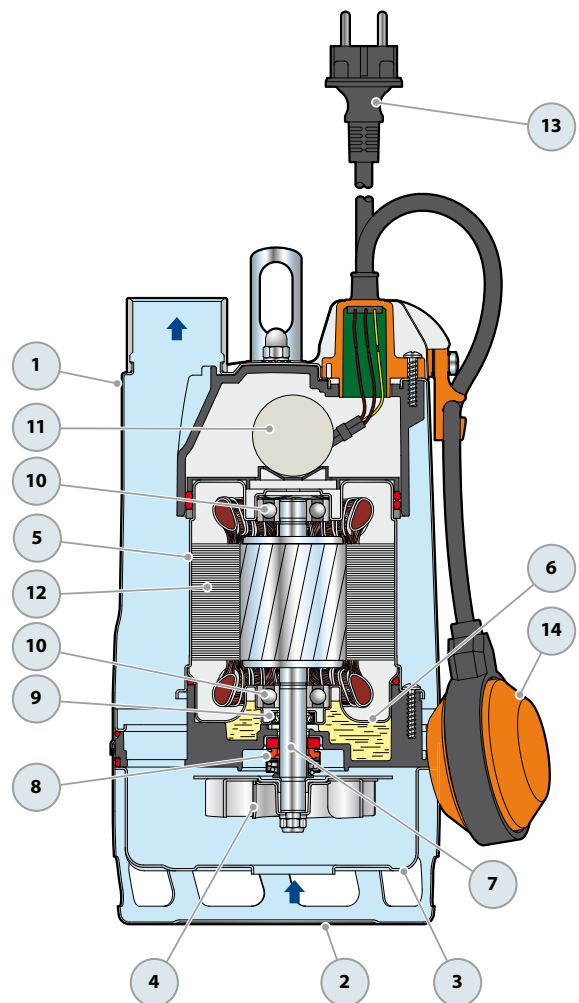

DIMENSIONS AND WEIGHT

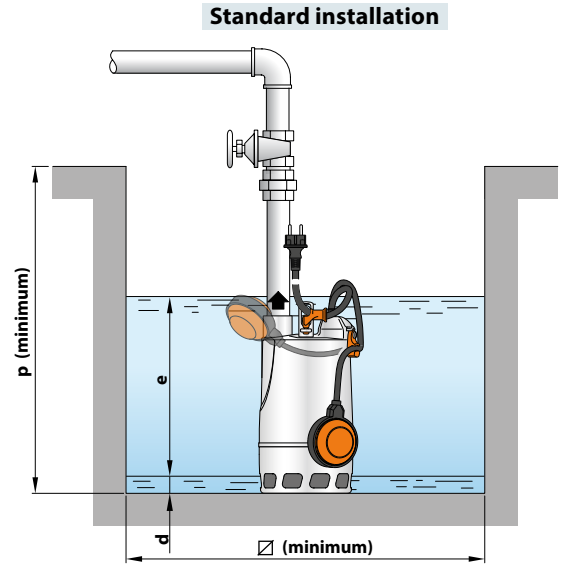
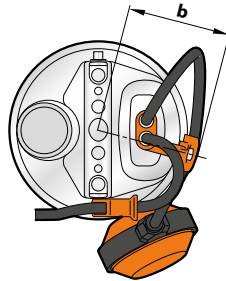
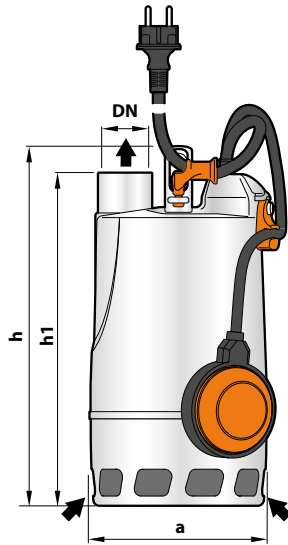

MODEL		PORT	DIMENSIONS mm								kg		PALLETIZATION	
Single-phase	Three-phase	DN	a	b	h	h1	d	e	p	Ø	1~	3~	GROUPAGE n. pumps	CONTAINER n. pumps
RXm 2/20	RX 2/20	1 1/4"	147	84	300	275	25	variable	350	350	6.2	5.8	96	144
RXm 3/20	RX 3/20				330	305								

Version with vertical float switch

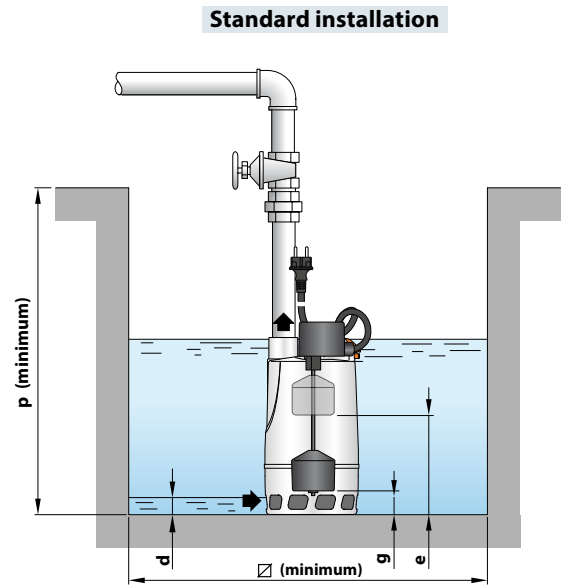
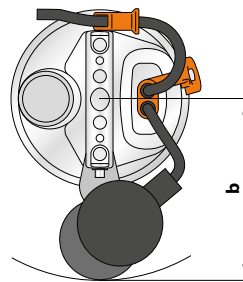
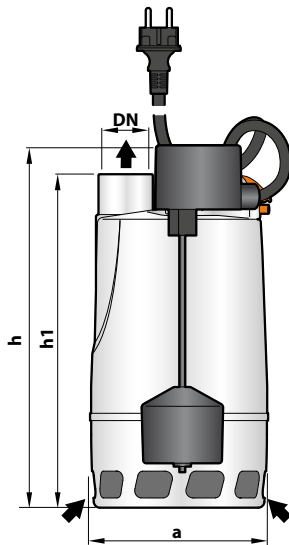

MODEL	PORT	DIMENSIONS mm									kg	PALLETIZATION	
Single-phase	DN	a	b	h	h1	d	e	g	p	Ø	1~	GROUPAGE n. pumps	CONTAINER n. pumps
RXm 2/20-GM	1 1/4"	147	150	302	275	25	180	50	350	240	6.3	96	144
RXm 3/20-GM				332	305		210	80					

ABSORPTION

MODEL	VOLTAGE		
Single-phase	220 V	110 V	127 V
RXm 2/20	2.5 A	5.0 A	4.8 A
RXm 3/20	3.5 A	7.0 A	6.6 A

MODEL	VOLTAGE		
Three-phase	220 V	380 V	440 V
RX 2/20	2.1 A	1.2 A	1.1 A
RX 3/20	3.0 A	1.7 A	1.5 A

POS. COMPONENT CONSTRUCTION CHARACTERISTICS

1	PUMP BODY	Stainless steel AISI 304 with threaded port in compliance with ISO 228/1
2	SUCTION FILTER	Stainless steel AISI 304
3	DIFFUSER	Stainless steel AISI 304
4	IMPELLER	Stainless steel AISI 304 VORTEX type
5	MOTOR CASING	Stainless steel AISI 304
6	MOTOR CASING PLATE	Stainless steel AISI 304
7	MOTOR SHAFT	Stainless steel AISI 431

8 SHAFT WITH DOUBLE MECHANICAL SEAL SEPARATED BY AN OIL CHAMBER

Seal Model	Shaft Diameter	Position	Materials		
			Stationary ring	Rotational ring	Elastomer
MG1-14D SIC	Ø 14 mm	Motor side	Silicon carbide	Graphite	NBR
		Pump side	Silicon carbide	Silicon carbide	NBR

9 BEARINGS 6203 ZZ-C3E / 6203 ZZ-C3E

CAPACITOR

Pump	Capacitance	
10 Single-phase	(220 V)	(110 V or 127 V)
RXm 4/40	20 µF - 450 VL	30 µF - 250 VL
RXm 5/40	25 µF - 450 VL	-

11 ELECTRIC MOTOR

RXm: single-phase 220 V - 60 Hz
with thermal overload protector incorporated into the winding

RX: three-phase 380 V - 60 Hz

- Insulation: class F
- Protection: IP X8

12 POWER CABLE

"H07 RN-F" type
(with Schuko plug for single-phase versions only)

Standard length 10 metres

13 FLOAT SWITCH

Only for single-phase versions
(Vertical float switch in the GM versions).

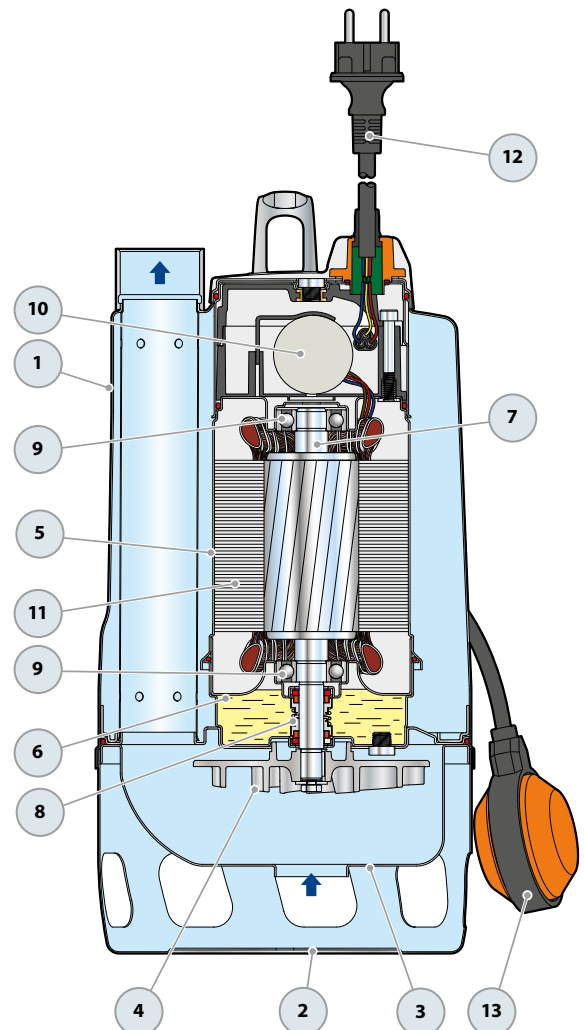

DIMENSIONS AND WEIGHT

Standard installation

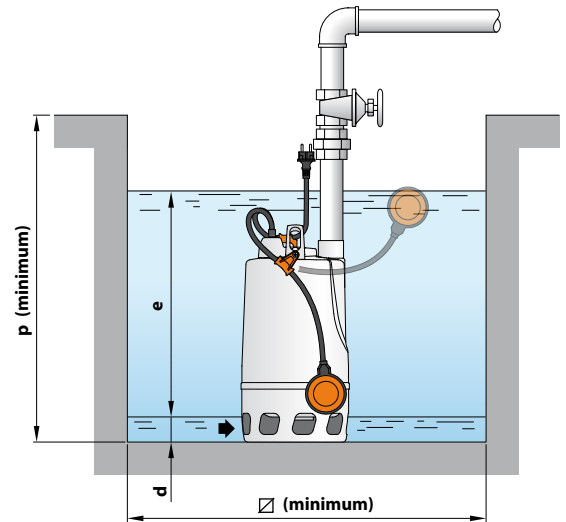
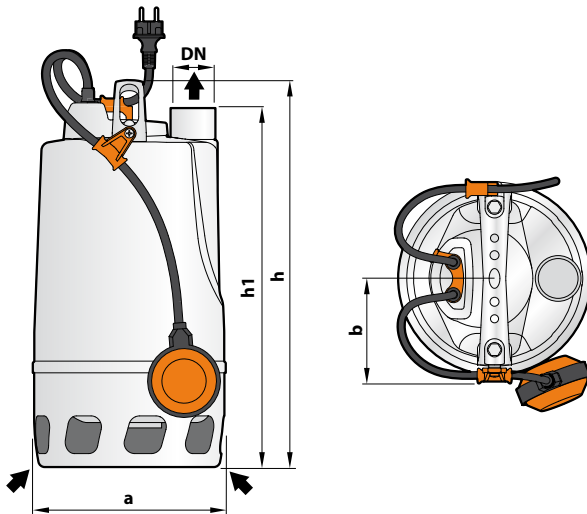

MODEL		PORT	DIMENSIONS mm								kg		PALLETIZATION	
Single-phase	Three-phase	DN	a	b	h	h1	d	e	p	Ø	1~	3~	GROUPAGE n. pumps	CONTAINER n. pumps
RXm 4/40	RX 4/40	1½"	215	115	432	400	50	variable	500	500	14.8	13.9	45	60
RXm 5/40	RX 5/40										16.0	15.1	45	60

Version with vertical float switch

Standard installation

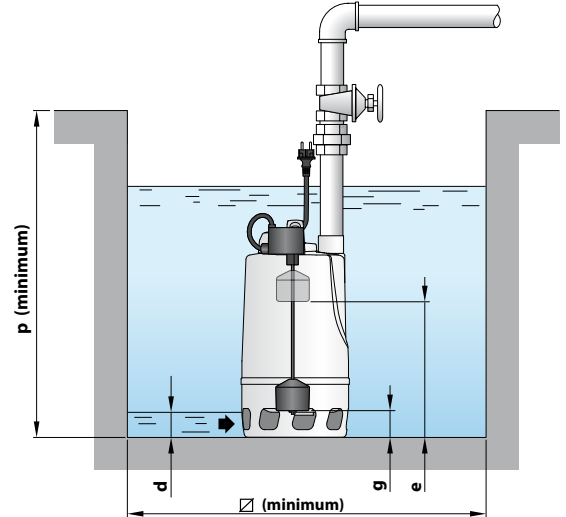
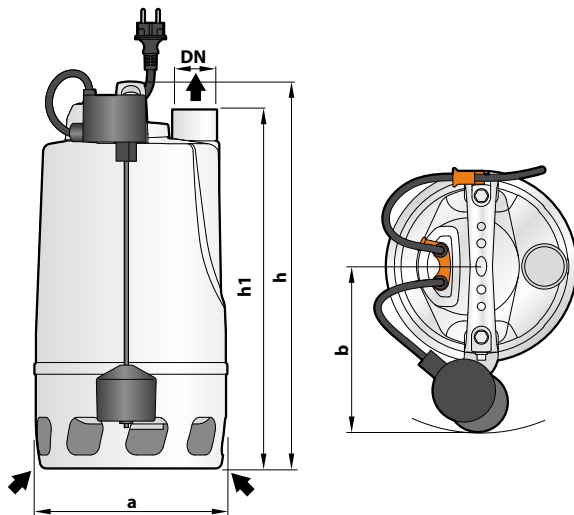

MODEL	PORT	DIMENSIONS mm										kg		PALLETIZATION	
Single-phase	DN	a	b	h	h1	d	e	g	p	Ø	1~	3~	GROUPAGE n. pumps	CONTAINER n. pumps	
RXm 4/40 - GM	1½"	215	186.5	433	434	50	320	80	500	350	15.2	15.2	36	48	
RXm 5/40 - GM											16.3	16.3	36	48	

ABSORPTION

MODEL	VOLTAGE		
Single-phase	220 V	110 V	127 V
RXm 4/40	5.0 A	10.0 A	8.7 A
RXm 5/40	7.5 A	-	-

MODEL	VOLTAGE		
Three-phase	220 V	380 V	440 V
RX 4/40	4.0 A	2.3 A	2.0 A
RX 5/40	6.0 A	3.5 A	3.1 A